

CREATING POWER SOLUTIONS.

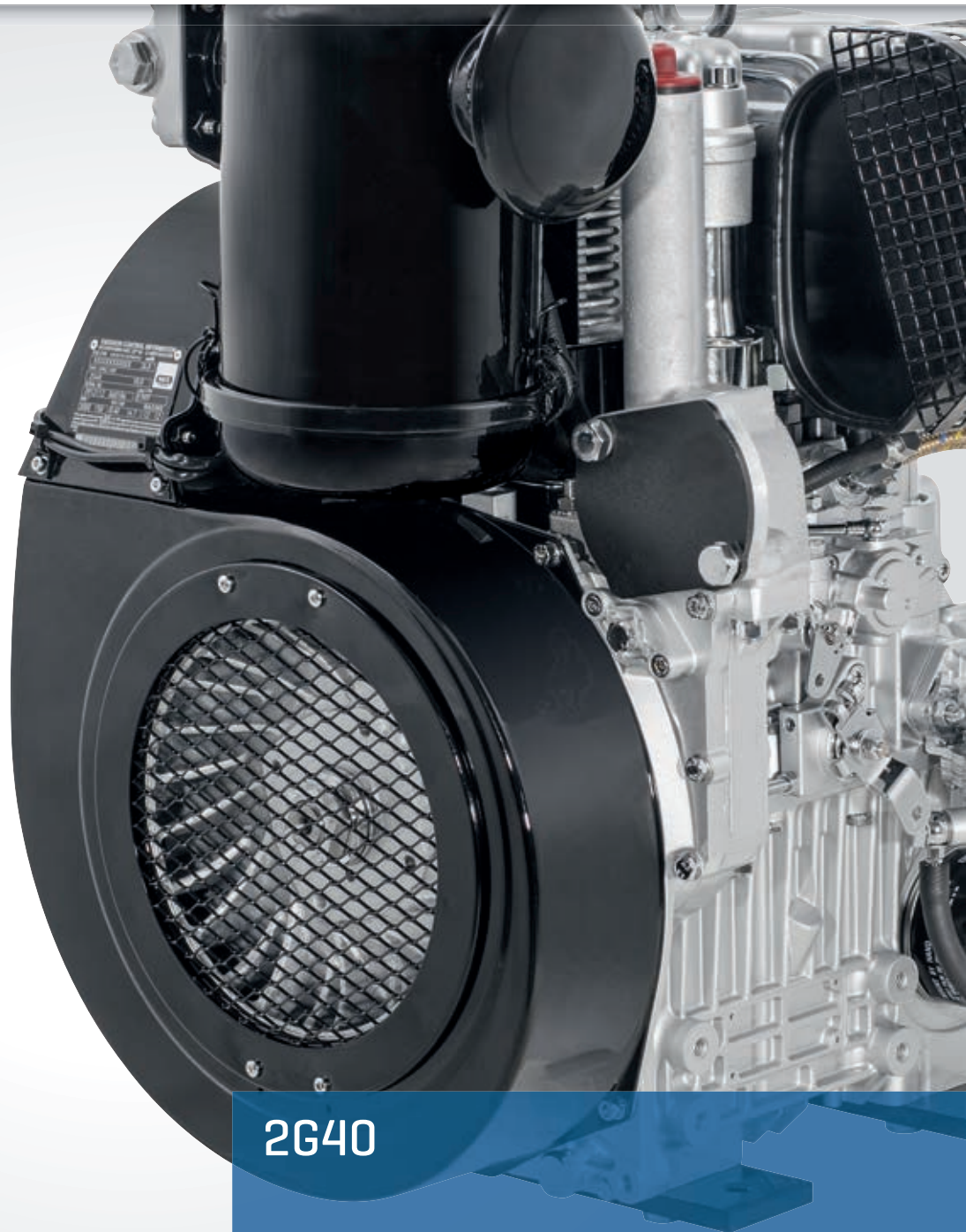

2G40

Hatz Diesel

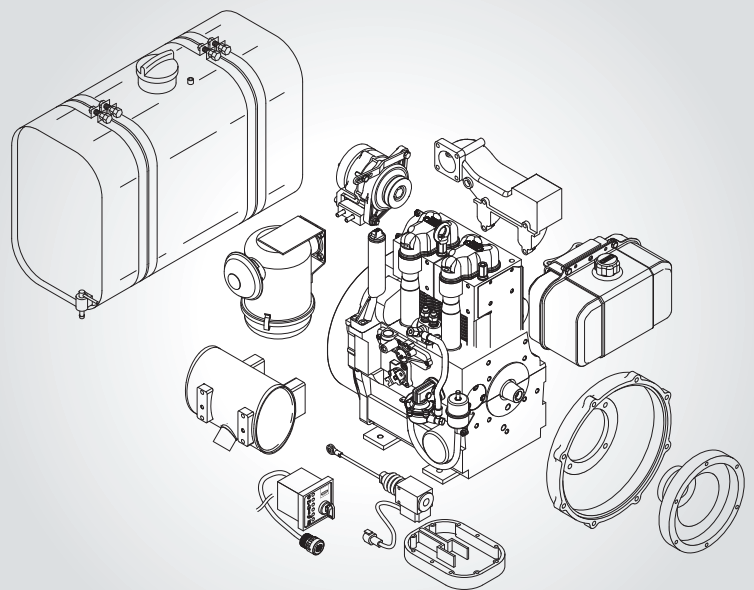
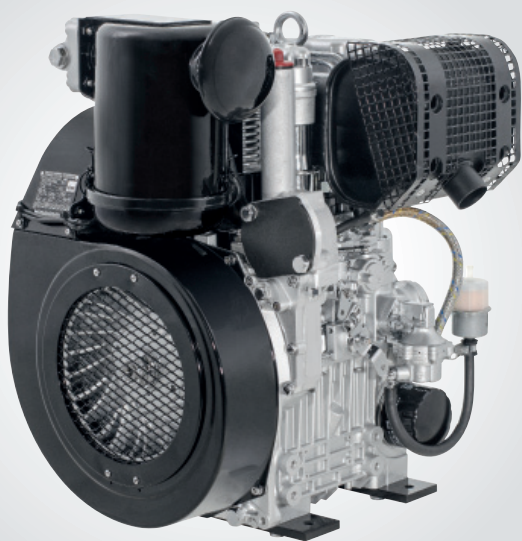

2640 · 2640H

On the 2640, power take off possibilities are available on the crankshaft [conical drive shaft] and directly on the flywheel. The 2640H version also provides a power take off with gear wheels for operating hydraulic pumps. The matching hydraulic pumps can, of course, also be obtained from Hatz.

Flexibility through additional equipment

Oil bath or dry air filter, additional oil sump, instrument box, fuel tanks, 12 V/24 V electrics and a number of connection housings. The list of standard available options is virtually endless.

Hatz G-series: The two-cylinder power package

As our customers can confirm, Hatz diesel engines are the most robust and durable in this market segment. Where they are installed makes no difference. Whether at very low temperatures or in a tropical climate, the Hatz 2G40 carries out its job reliably. With regular maintenance many thousands of hours are commonplace, using Hatz original spare parts, of course.

Lightweight and compact

Like all Hatz diesel engines, the extremely compactly built two-cylinder engine is distinguished by its high reliability and, not least, flexible in application thanks to its dimensions. The light metal construction of the housing and die-cast aluminum cylinder heads keep the weight low, between 88 kg and 105 kg depending on the version.

Low operating costs

The air cooled 2G40 is the absolute front runner in terms of total operating costs. This is due not only to the low fuel and engine oil consumption, but also to the remarkably low maintenance costs. For example, the engine does without any belts at all. In the basic version with oil bath filter, just the fuel and engine oil filter as well as the engine oil are all that need to be changed regularly.

Environmental aspects

The Hatz 2G40 is exclusively produced and marketed to the specification of the strict US exhaust standard of the EPA (Environmental Protection Agency). Measures for reducing inner engine friction losses result in high efficiency, and thus also in an extremely low specific fuel consumption.

Robust and durable design



Hatz engines are designed for an exceptionally long service life. The best possible materials and components coupled with uncompromising quality assurance contribute to the fact that Hatz engines have

been setting standards in the industry for many years when it comes to robustness and service life. And should, contrary to expectations, a spare part actually be needed, more than 500 service partners in 115 countries are available quickly and dependably with advice and assistance as well as original spare parts.

IFN rating ICFN rating F/IFN/ICFN rating

Sales area [exhaust certificate]		2G40	
USA [EPA/CARB constant speed]	[r.p.m.]	2000-3000	
USA [EPA 2-speed]	[r.p.m.]	2300-3000	
USA [EPA variable speed]	[r.p.m.]	2300-3000	
India CPCB I [Genset]	[r.p.m.]	3000	
All others [non-EPA]	[r.p.m.]	1500-3600	

Technical data, Performance Table

Technical data		2640				
Engine	Type	Air cooled 2-cylinder 4-stroke diesel engine with direct injection				
	Bore x stroke [mm / inches]	92 x 75 / 3.62 x 2.95				
	Displacement [l / cu.in.]	0.997 / 60.84				
	Mean piston speed at 3000 r.p.m. [m/s / ft/min]	7.5 / 1476				
	Compression ratio	20.5 : 1				
	Lub. oil consumption, related to full load	approx. 1 % of fuel consumption				
	Oil filling max - min [l / US qts]	2.5 - 1.7 / 2.6 - 1.8				
	Speed control					
	• Lowest idle speed	approx. 1000 r.p.m.				
• Static speed droop	approx. 5% at 3000 r.p.m.					
Installation information	Amount of combustion air at 3000 r.p.m. approx. ¹⁾ [m ³ /min / cu.ft./min]	1.42 / 50.3				
	Amount of cooling air at 3000 r.p.m. approx. ¹⁾ [m ³ /min / cu.ft./min]	10.5 / 370				
	Mass moment of inertia J [kgm ² / lb.ft ²]	0.16 / 3.78				
	Starter	12 V - 2.0 kW — 24 V - 3.0 kW				
	Alternator charging current at 3000 r.p.m. 1500 r.p.m.	14 V - 23 A, 28 V - 12 A — 14 V - 55 A, 28 V - 27 A 14 V - 10 A, 28 V - 5 A — 14 V - 55 A, 28 V - 27 A				
Battery capacity [min / max Ah]	12 V - 45Ah / 88 Ah — 24 V - 45 Ah / 55 Ah					
Weight		Engine with rope start	Engine with electric start 12 V, flywheel alternator 23 A	Engine with electric start 24 V, flywheel alternator 12 A	Engine with electric start 12 V, belt-driven alternator 55 A	Engine with electric start 24 V, belt-driven alternator 27 A
	Weight of engine versions [kg / lbs.]	88.8 / 195.8	96.8 / 213.4	99.1 / 218.58	103.4 / 228.0	105.2 / 232.0

¹⁾ For other speeds there is a linear reduction in the air requirement.

Performance Table		2640	
	[r.p.m.]	kW	hp
Vehicle power acc. to DIN ISO 1585. [kW / hp]	3600	17.0	23.1
	3000	16.2	22.0
	2600	14.6	19.9
Blocked ISO brake horsepower [IFN] for heavily intermittent loading acc. to ISO 3046-1. [kW / hp]	3600	16.3	22.2
	3000	15.5	21.1
	2600	13.9	18.9
Blocked ISO brake horsepower [IFN] for intermittent loading acc. to ISO 3046-1. [kW / hp]	3600	15.6	21.2
	3000	14.7	20.0
	2600	13.4	18.2
EPA 2-Speed	2300	12.0	16.3
	2000	10.5	14.3
	1800	9.3	12.6
	1500	7.4	10.1
ISO standard power output [ICXN] [10% overload permissible]. [kW / hp]	3000	13.7	18.6
	2600	12.6	17.1
EPA variable; EPA constant	2300	11.2	15.2
Blocked ISO standard power output (no overload permissible) acc. to ISO 3046-1. [kW / hp] For constant speed and constant load [ICFN].	2000	9.8	13.3

Power output, torque und fuel consumption

2G40

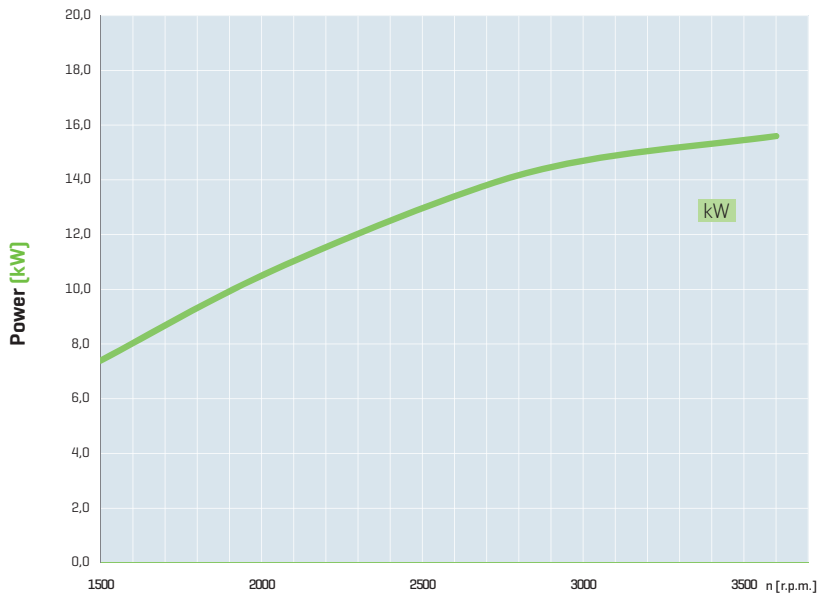
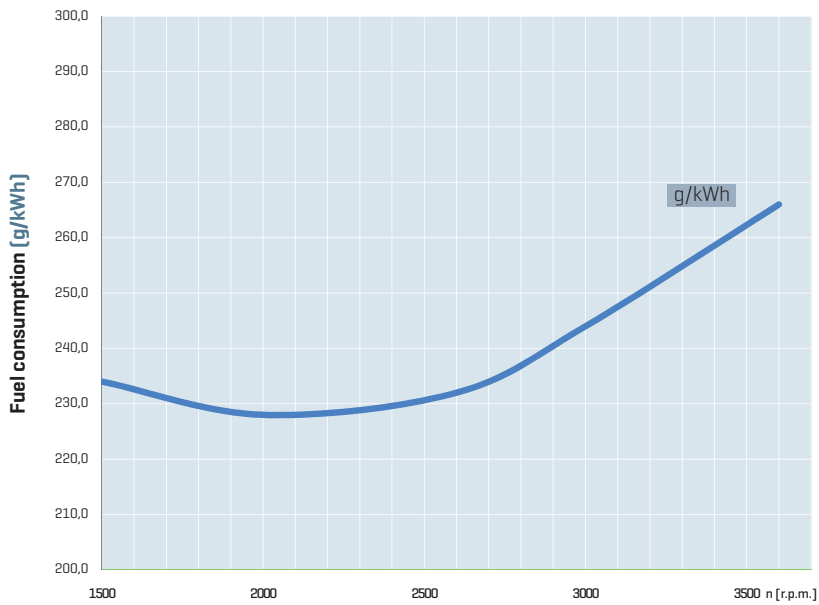
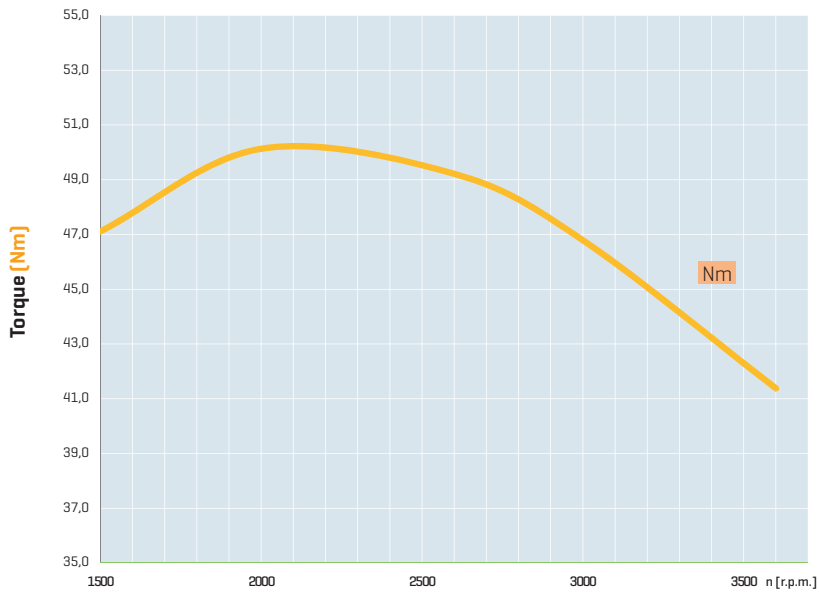

Power ratings

Power ratings refer to standard reference conditions of ISO 3046-1 (IFN): + 25 °C (77 °F), 100 kPa, relative humidity 30 %. The specified power is reached during the running-in period, and can be 5 % less on delivery. Power reduction acc. to ISO 3046-1. Standard values: More than 100 m above sea level approx. 1 % per 100 m. Above 25 °C (77 °F) approx. 4 % per 10 °C (50 °F). The power taken from the alternator also has to be added to the power calculation.

Maintenance and operating points

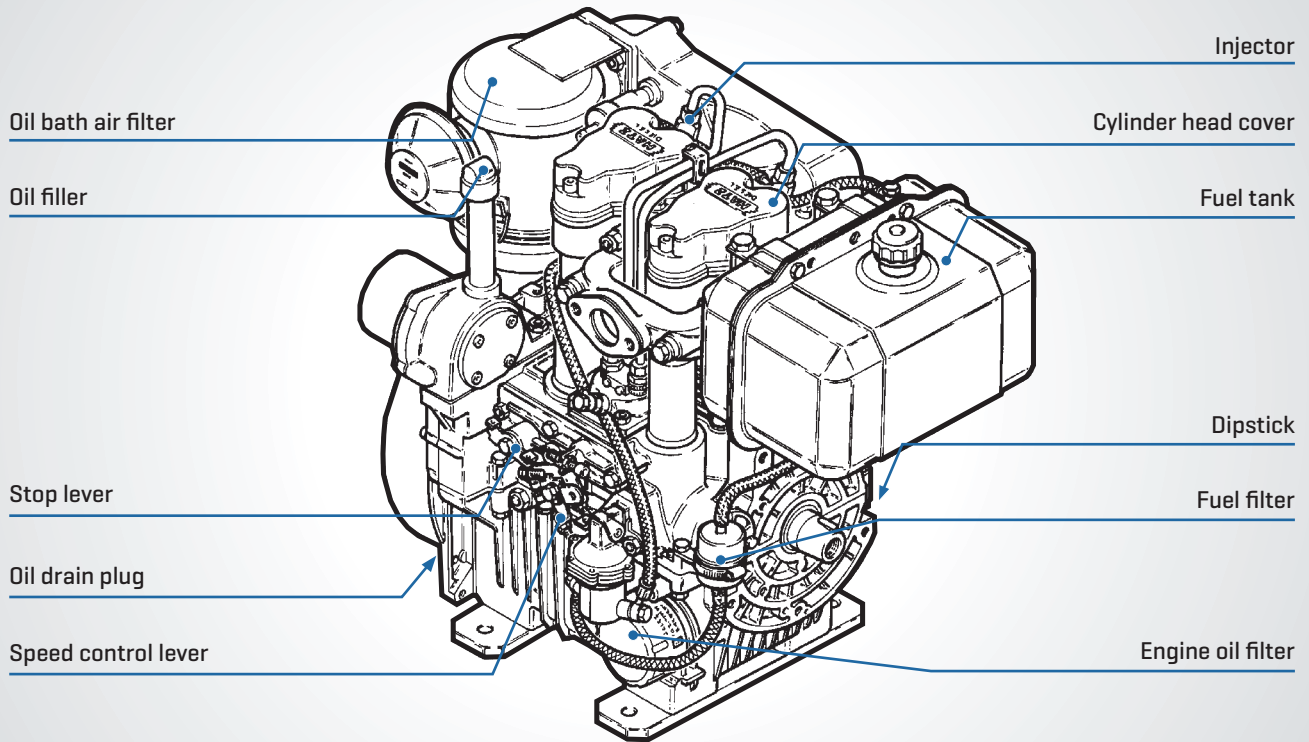

Power take off

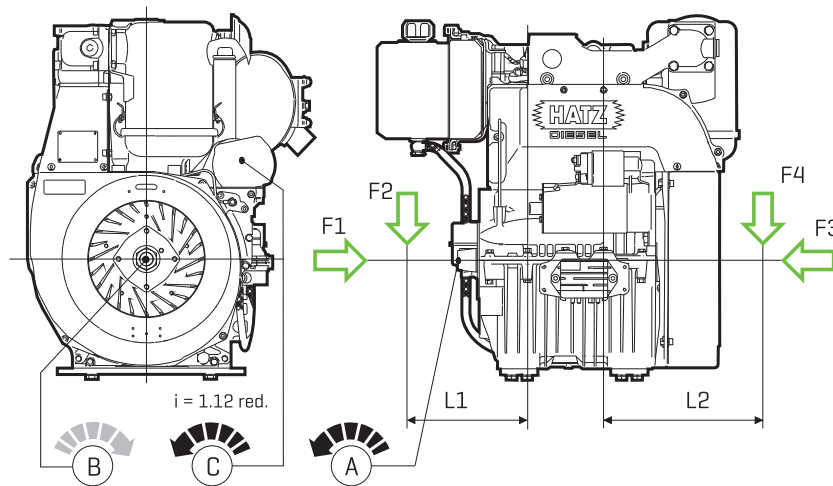

Power take off		2640
Transferable torque	A	100%
	B	100%
	C	30.6 Nm
Permissible load	F1	3400 N
	F2	$F2 = \frac{261\,000}{L1 \text{ [mm]}}$ [N]*
	F3	3400 N
	F4	$F4 = \frac{293\,000}{L2 \text{ [mm]}}$ [N]*

*] with upward belt pull values reduced to 55 %.

Dimensions

2G40

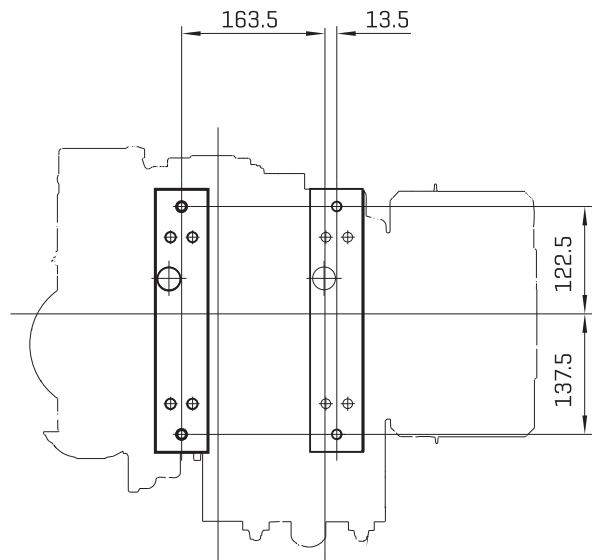
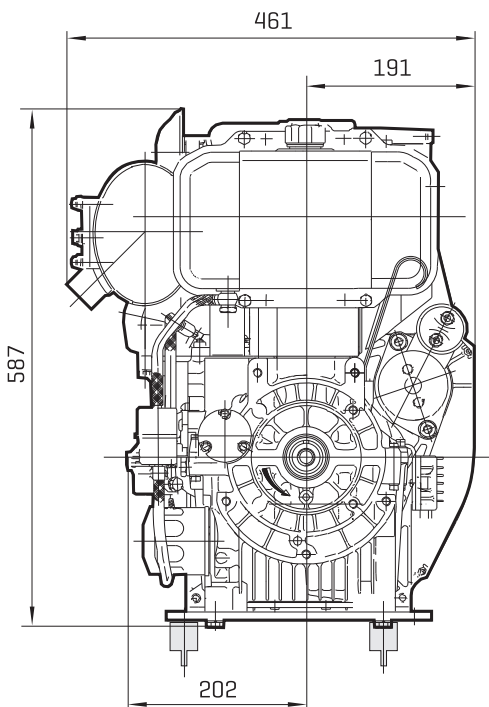
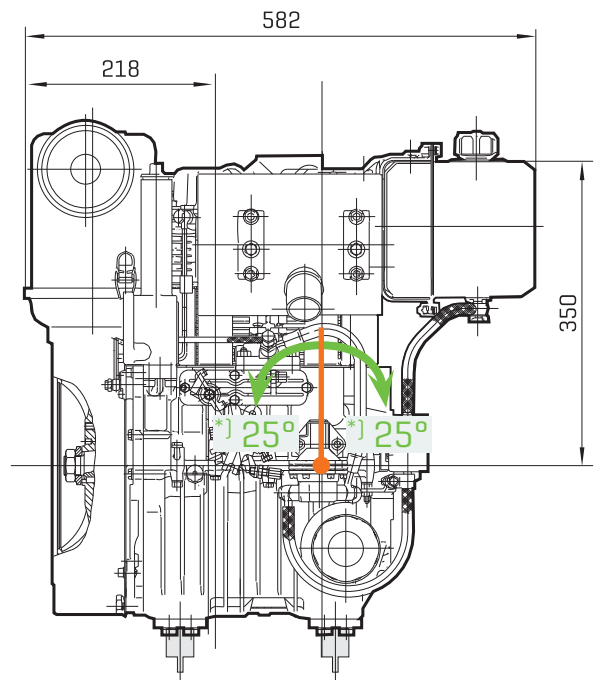
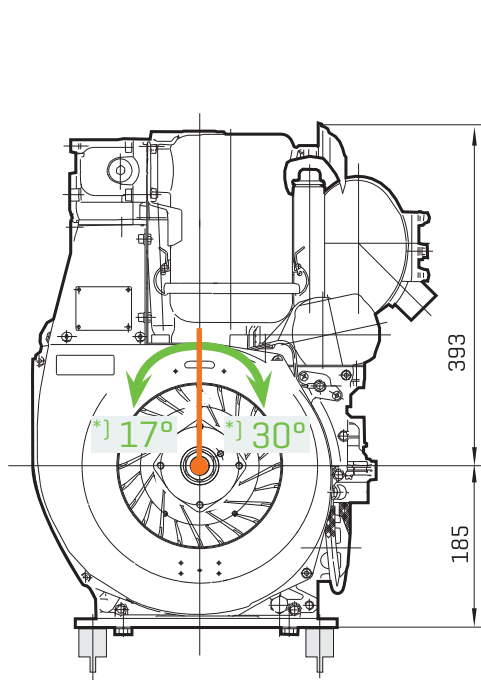

Spread at box dimensions ± 3 mm due to tolerance.
Drawings with detail and connection dimensions as PDF resp. DXF
can be found at www.HATZ-DIESEL.com.

*] Max. tilt position

Motorenfabrik Hatz GmbH & Co. KG
Ernst-Hatz-Str. 16
94099 Ruhstorf a.d. Rott
Germany
Phone +49 8531 319-0
Fax +49 8531 319-418
marketing@hatz-diesel.de
www.hatz-diesel.com



CREATING POWER SOLUTIONS.

700 384 76 EN-06.13-2 Printed in Germany
Modifications, which serve technical
improvement, are reserved.