

KDI

KOHLER DIRECT INJECTION



KOHLER®



STARTING FROM A CLEAN SHEET, THE KOHLER STRATEGY FOR THE DESIGN OF THE NEW KDI ENGINE FAMILY HAS BEEN FOCUSED ON UTILISING STATE OF THE ART

TECHNOLOGY TO CONTROL THE COMBUSTION PROCESS TO PROVIDE A BEST IN CLASS ENGINE BOTH FOR PERFORMANCE AND ALSO EXHAUST GAS EMISSIONS.



EXCELLENT POWER AND TORQUE CHARACTERISTICS WILL NOT ONLY PROVIDE CUSTOMERS WITH OPPORTUNITIES TO DOWN-SIZE FROM THEIR CURRENT ENGINE

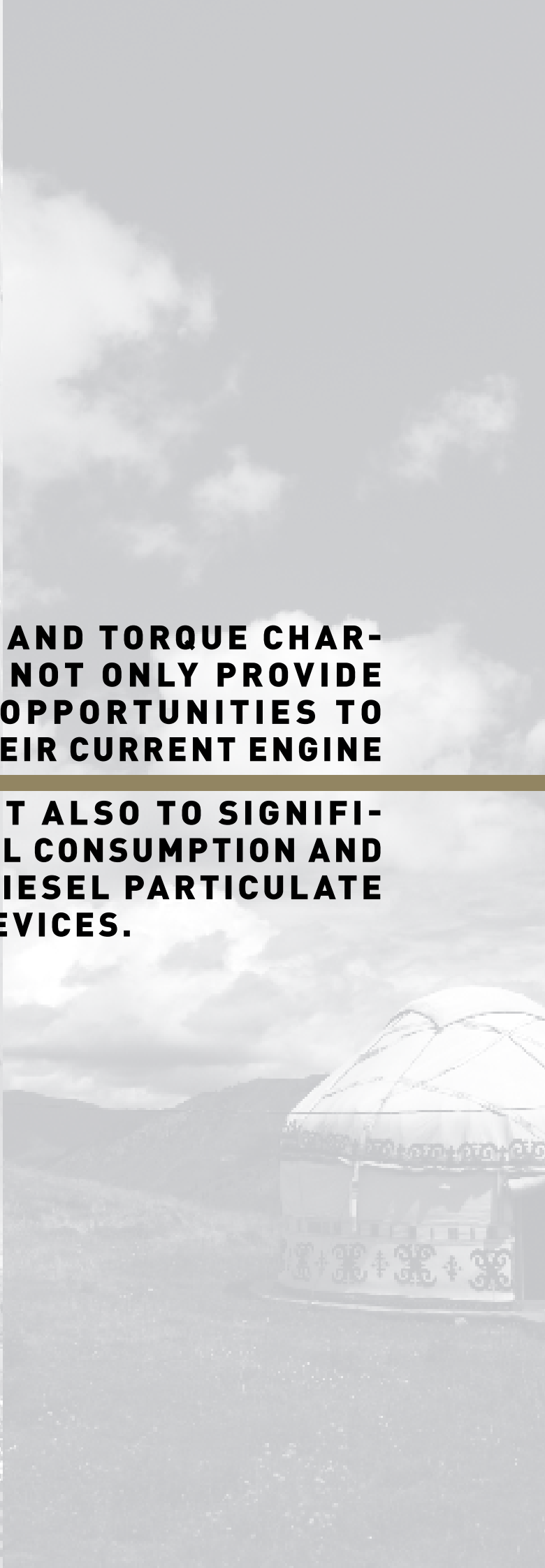

DISPLACEMENT, BUT ALSO TO SIGNIFICANTLY REDUCE FUEL CONSUMPTION AND AVOID EXPENSIVE DIESEL PARTICULATE FILTRATION (DPF) DEVICES.

COMMON-RAIL SYSTEM

Kohler has selected the most advanced common-rail system available on the market and specifically engineered for extreme durability and longevity within arduous industrial and construction equipment applications. The 2000 bar high pressure pump, together with the advanced multiple-injection control of the solenoid-injectors, allows an excellent fuel rate control during the injection process.

TURBOCHARGER AND CHARGE-AIR COOLER

The waste-gated turbocharger has been specifically tuned to minimize the turbo-lag response and provide the precise volume of air for an excellent low end torque capability. The special design of the lubrication system guarantees extended durability of the turbocharger. The use of a charge air cooler is required to ensure the correct air inlet temperature for the optimal engine performance whilst achieving emissions compliance.

4 VALVES

The 4 valves per cylinder design has been selected to enable the installation of the injectors precisely on the cylinder axis and centred with the combustion bowl. This solution allows for a symmetrical fuel atomisation and distribution within the combustion bowl ensuring optimal mixing of fuel and air. The design of the combustion bowl itself together with the inlet ports shaping, have been studied and developed with CFD analysis to complete the absolute optimization of the combustion process.



INNOVATIONS

ECU

The engine electronic control unit (ECU), together with the common rail injection system, is a part of the most advanced automotive style engine management system and has been specifically developed for industrial and construction equipment applications. It allows a full control of the engine calibration parameters to achieve the engine performances and emissions targets. A CAN bus link allows the ECU to interface with other electronic systems within the final application in order to optimize the engines operating parameters. Options of specific functionalities have been enabled within the ECU in order to provide OEMs with different governing characteristics ensuring total compatibility with individual equipment.

EGR SYSTEM

The Exhaust Gas Recirculation (EGR) system has been designed with CFD analysis and the use of comprehensive research and development resources. So significant has been the final design of the EGR process it has the status of patent pending. The chosen design of a "hot side" EGR layout will avoid valve sticking problems that are historically the most common failures seen within these systems. Exhaust gas routing across the cylinder head ensures a beneficial preliminary gas cooling before entering the EGR valve to reduce the overall dimensions of the unit to assist installation parameters.

TIER 4 FINAL COMPLIANCE

EXCELLENT FUEL EFFICIENCY

LONG SERVICE INTERVALS

EASY MAINTENANCE



BENEFITS

LOW VIBRATIONS

REDUCED NOISE

COMPACT

NO AFTER TREATMENT, NO HEAT REGENERATION

TURBO COMMON RAIL ENGINES



STANDARD EQUIPMENT

Intake manifold
Exhaust manifold
Side oil refilling
Electric starter
80A alternator
SAE 4 (7" ½)
Cabin heating predisposition
Fuel and oil filter engine mounted
Fuel filter with water sensor and priming pump
Environmentally friendly oil filter
ECU
Oil sump capacity 8.5 L (KDI 1903) and 11.3 L (KDI 2504)

ACCESSORIES ON DEMAND

Diesel oxidation catalyst (DOC)
Charge air-cooler
Remote fuel and oil filter
Protections required by the type of use
Clutch flywheels
SAE 3 (11" ½)
SAE 5 (6" ½)
Plate flangers
Transmission adapters
Radiators
Mounting feet
Heavy duty air cleaner
Dynamic balancing (KDI 2504)
Throttle pedal sensor



KDI 1903TCR

QUICK SPECIFICS

3 CYLINDER Turbo common rail

56 HP | **42** kW @ 2600 rpm
TIER 4 final
STAGE III B

225 Nm @ 1500 rpm



DATA

DIMENSIONS (mm)

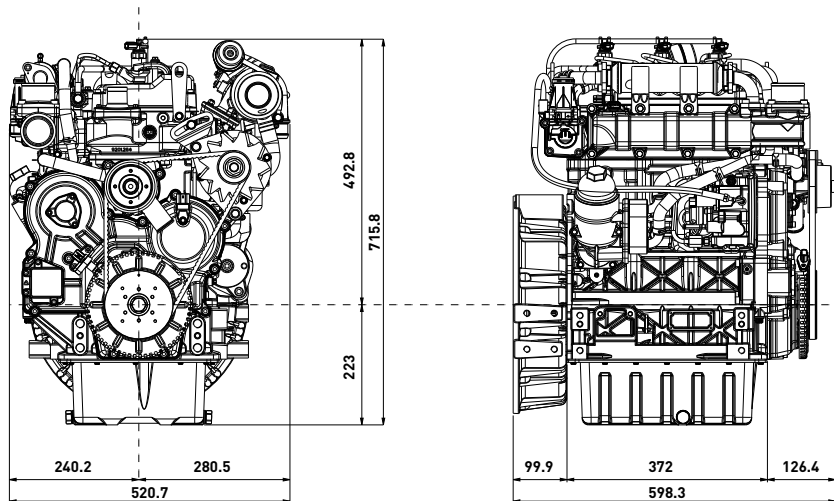

PERFORMANCE CURVES (NB-ACCORDING TO ISO 14396)

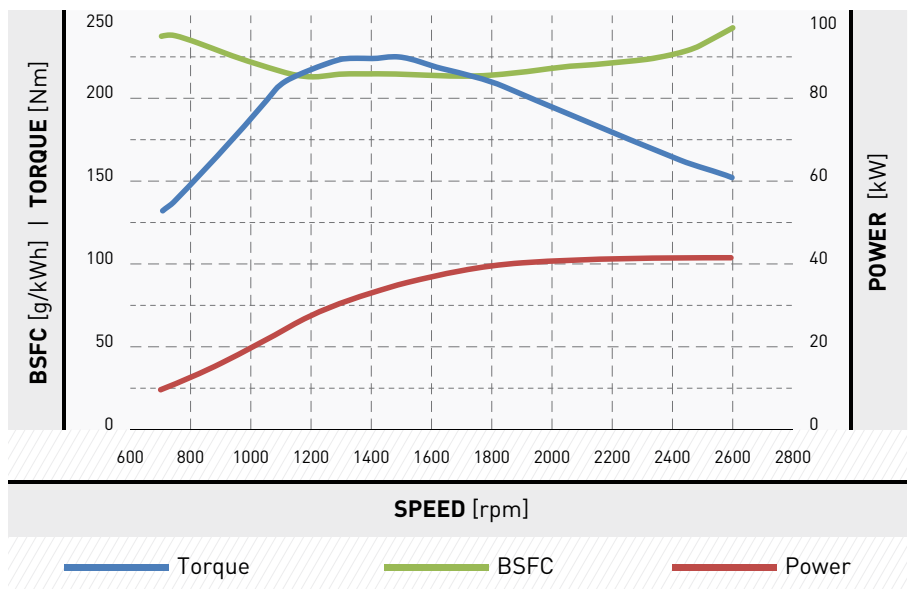

GENSET RATINGS

(rpm)	Gross engine stand-by power (kW)	Engine prime power (kW)
1800 Tier 4 final	37.0	32.0
1500 Stage III B	28.5	24.9



KDI 2504 TCR

QUICK SPECIFICS

4 CYLINDER Turbo common rail

74 HP | **55** kW @ 2600 rpm
TIER 4 final
STAGE III B

300 Nm @ 1500 rpm

DATA

DIMENSIONS (mm)

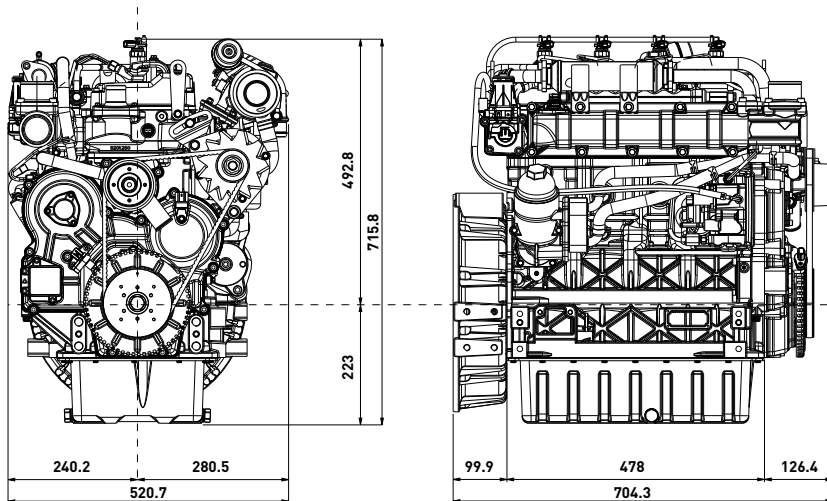

PERFORMANCE CURVES (NB-ACCORDING TO ISO 14396)

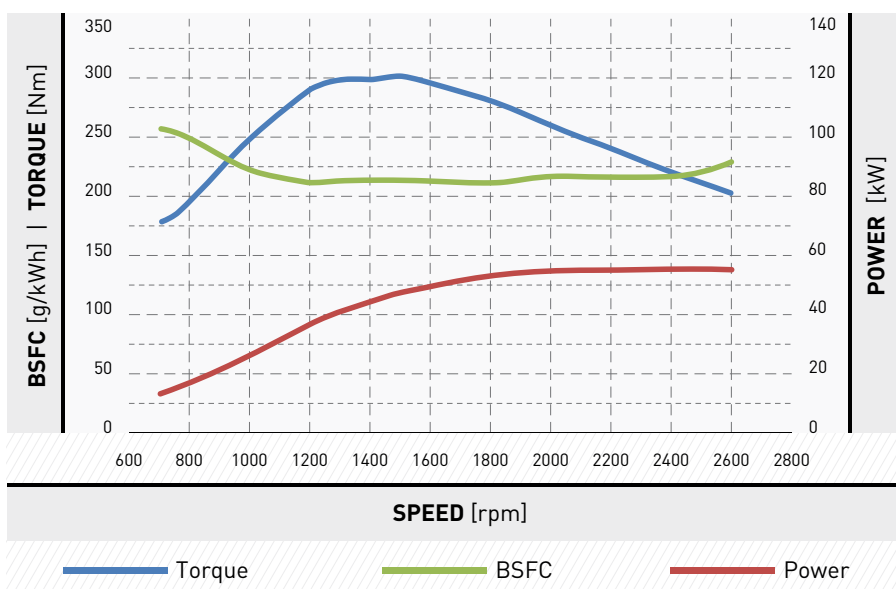

GENSET RATINGS

(rpm)	Gross engine stand-by power (kW)	Engine prime power (kW)
1800 Tier 4 final	47.1	41.1
1500 Stage III B	39.5	34.5

MECHANICAL ENGINES



STANDARD EQUIPMENT

Intake manifold
Exhaust manifold
Side oil refilling
Electric starter
55A alternator
SAE 4 (7" ½)
Cabin heating predisposition
Fuel and oil filter engine mounted
Oil sump capacity 8.5 L (KDI 1903)
and 11.3 L (KDI 2504)

ACCESSORIES ON DEMAND

Remote fuel and oil filter
Protections required by the type of use
Clutch flywheels
SAE 3 (11" ½)
SAE 5 (6" ½)
Plate flangers
Transmission adapters
Radiators
Mounting feet
Heavy duty air cleaner
Dynamic balancing (KDI 2504)



KDI 1903M

QUICK SPECIFICS

3 Mechanical Engine
CYLINDER

42 | **31** @ 2800 rpm
HP | kW Stage III A

133 @ 1500 rpm
Nm



DATA

DIMENSIONS (mm)

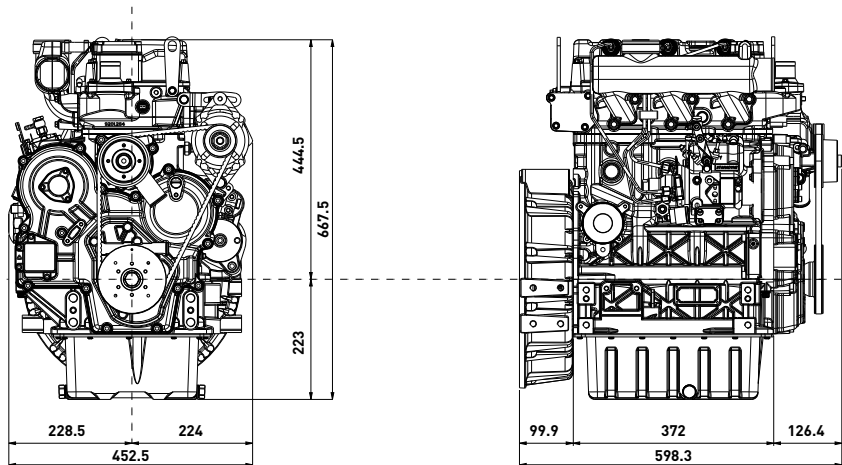

PERFORMANCE CURVES (NB-ACCORDING TO ISO 14396)

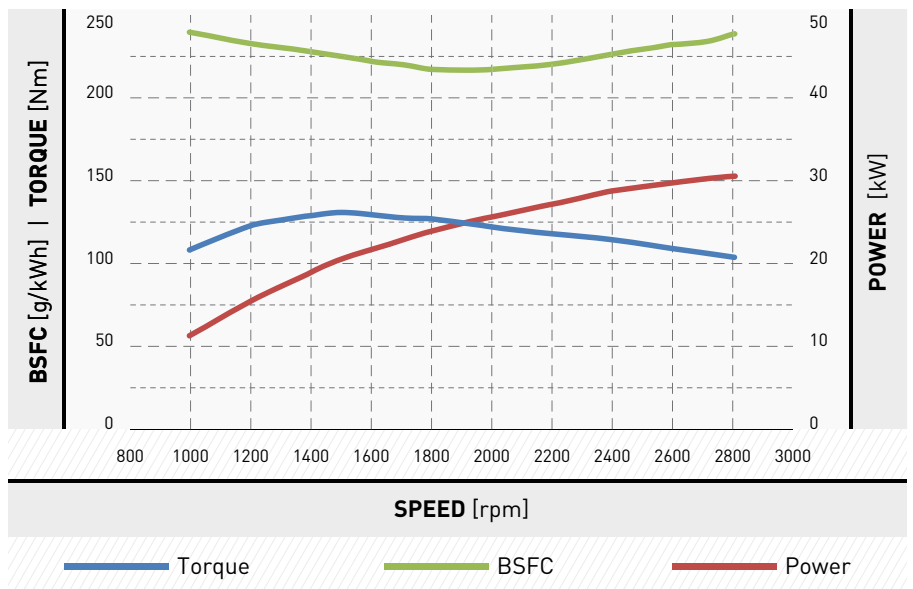

GENSET RATINGS

(rpm)	Gross engine stand-by power (kW)	Engine prime power (kW)
1800 Tier 4 Interim	24.2	20.4
1500 Tier II Stage III A	21.0	18.0



KDI 2504M

QUICK SPECIFICS

4 Mechanical Engine
CYLINDER

49 | **36** @ 2800 rpm
HP | kW Stage III A

55 | **41** @ 2800 rpm
HP | kW Tier II

170 @ 1500 rpm
Nm

DATA

DIMENSIONS (mm)

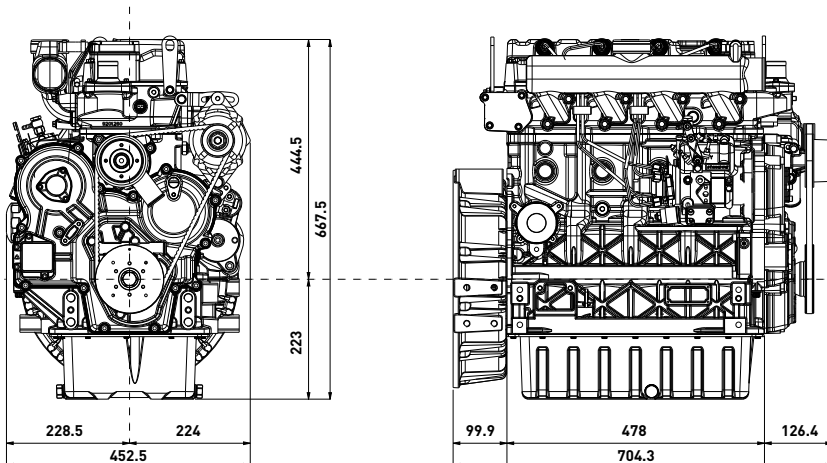

PERFORMANCE CURVES (NB-ACCORDING TO ISO 14396)

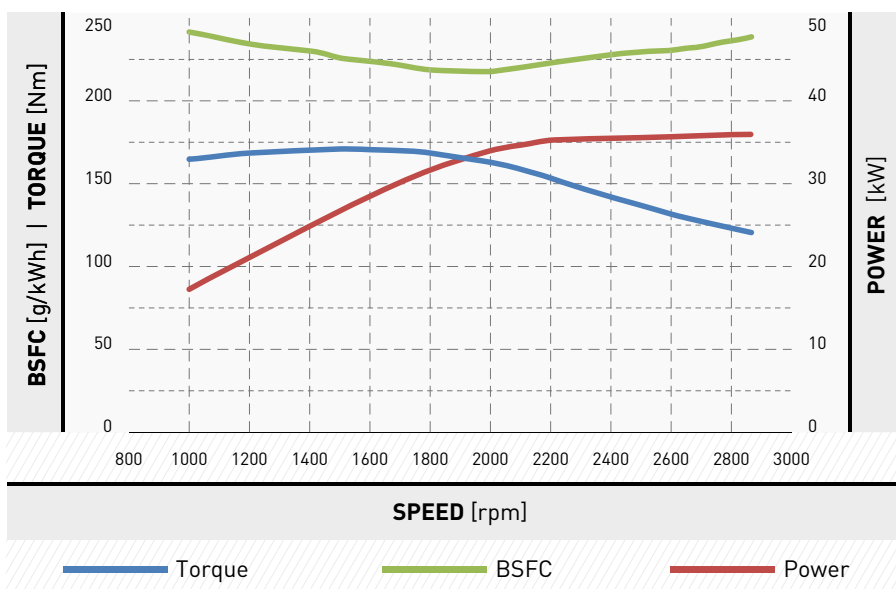

GENSET RATINGS

(rpm)	Gross engine stand-by power (kW)	Engine prime power (kW)
1800 Tier 4 Interim	32.4	27.8
1500 Tier II Stage III A	27.0	23.6

TURBO COMMON RAIL ENGINES



Model		KD11903TCR	KD12504TCR
Engine specs	4 stroke diesel with cylinder in line	•	•
	Liquid cooling	•	•
	4 valves per cylinder	•	•
	In crankcase camshaft, gear train driven	•	•
	Pushrod - rocker arms timing with hydraulic tappets	•	•
	Cast iron crankcase with bed-plate	•	•
	Closed crankcase ventilation system	•	•
	High pressure common rail (2000 bar)	•	•
	Electronic engine management	•	•
	Waste-gate turbocharger	•	•
	Charge-air cooling	(•)	(•)
Technical features	Cylinder	3	4
	Bore (mm)	88	88
	Stroke (mm)	102	102
	Engine displ (cm ³)	1861	2482
	Injection system	DI	DI
	Injection Equipment	Common rail (2000 bar)	Common rail (2000 bar)
	Emission compliance	TIER 4 final / STAGE III B	TIER 4 final / STAGE III B
Performance	Max power (ISO 14396) (kW@rpm)	42@2600	55.4@2600
	Max torque (Nm@rpm)	225@1500	300@1500
	Low-end torque (Nm@1000 rpm)	190	260
Fuel economy	Best point (g/kWh)	210	210
	Max power (g/kWh@2600)	235	235
Startability	Unaided (°C)	-20	-20
	Aided* (°C)	-30	-30
	* Manifold grid heater		
Fuel compatibility	UNI EN 590-2010	•	•
	No 1 Diesel (US) - ASTM D 975-09 B - Grade 1-D S 15	•	•
	No 2 Diesel (US) - ASTM D 975-09 B - Grade 2-D S 15	•	•
	Arctic EN 590/ASTM D 975-09 B (No petroleum added)	•	•
Service features	Oil/filter change interval std/synthetic (hr)	500-750*	500-750*
	Valve adjustment	—	—
	Alternator belt replacement	36mth	36mth
	Coolant change	24 mth	24 mth
	Oil consumption (% fuel)	<0.1	<0.1
	* according to operating conditions		
Physical characteristics	H x L x W (fan excluded) (mm)	715.8 x 598.3 x 520.7	715.8 x 704.3 x 520.7
	Weight (kg)	233	267
	Daily service points - positions	1 side service	1 side service
	Ambient operating temps (°C)	-40 to +50	-40 to +50
	Gradeability-all round (continuous) (deg)	25	25
	Gradeability-all round (intermitent-1min) (deg)	35	35
Cooling & lubrication	Heat rejection to coolant (includes oil cooler) (kW)	32	44
	Cooling fluid: 50/50 water/antifreeze	•	•
	Oil type	SAE 5W 30 low SAPS EURO 6 API CJ-4	SAE 5W 30 low SAPS EURO 6 API CJ-4
Vibration	Max engine excitation at mounting locations	5g	5g
Options	Brand	Kohler/Lombardini	Kohler/Lombardini
Auxiliary PTOs (3rd & 4th optional)	Max torque (Nm)	100	100
	Drive ratio	1.23 times engine speed	1.23 times engine speed
	Provision for a double Gr:2 tandem hydraulic pump	•	•

MECHANICAL ENGINES



Model		KDI1903M	KDI2504M	KDI2504TM
Engine specs	4 stroke diesel with cylinder in line	•	•	•
	Liquid cooling	•	•	•
	4 valves per cylinder	•	•	•
	In crankcase camshaft, gear train driven	•	•	•
	Pushrod - rocker arms timing with hydraulic tappets	•	•	•
	Cast iron crankcase with bed-plate	•	•	•
	Cast iron cylinder head	•	•	•
	Closed crankcase ventilation system	•	•	•
	Waste-gate turbocharger	—	—	•
	Charge air cooling	—	—	(•)
Technical features	Cylinder	3	4	4
	Bore (mm)	88	88	88
	Stroke (mm)	102	102	102
	Engine displ (cm ³)	1861	2482	2482
	Injection system	DI	DI	DI
	Injection Equipment	Mech-Rotary pump	Mech-Rotary pump	Mech-Rotary pump
	Emission compliance	STAGE III A	STAGE III A	STAGE III A
Performance	Max power (ISO 14396) (kW@rpm)	31@2800	36.4@2800 (STAGE III A) 41@2800 (TIER 2)	55.4@2800 (STAGE III A) 62@2800 (TIER 2)
	Max torque (Nm@rpm)	133@1500	170@1500	250@1500
	Low-end torque (Nm@1000 rpm)	125	165	200
Fuel economy	Best point (g/kWh)	220	220	215
	Max power (g/kWh@2600)	240	240	240
Startability	Unaided (°C)	-20	-20	-20
	Aided* (°C)	-30	-30	-30
	* Manifold grid heater			
Fuel compatibility	UNI EN 590-2010	•	•	•
	No 1 Diesel (US) - ASTM D 975-09 B - Grade 1-D S 15	•	•	•
	No 1 Diesel (US) - ASTM D 975-09 B - Grade 1-D S 500	•	•	•
	No 2 Diesel (US) - ASTM D 975-09 B - Grade 2-D S 15	•	•	•
	No 2 Diesel (US) - ASTM D 975-09 B - Grade 2-D S 500	•	•	•
	ARCTIC EN 590/ASTM D 975-09 B	•	•	•
	High Sulfur Fuel < 5000 ppm (< 0.5%)	•	•	•
	High Sulfur Fuel > 5000 ppm (> 0.5%)	•	•	•
	Military NATO Fuels F34 - F35 - F44 - F63 - F64 - F65 *	•	•	•
	Military US Fuels JP5 - JP8 (AVTUR) *	•	•	•
	Civil Jet Fuels Jet A/ A1*	•	•	•
	* With restrictions			
Service features	Oil/filter change interval std/synthetic (hr)	500-750*	500-750*	500-750*
	Valve adjustment	—	—	—
	Alternator belt replacement	36mth	36mth	36mth
	Coolant change	24 mth	24 mth	24 mth
	Oil consumption (% fuel)	<0.1	<0.1	<0.1
	* according to operating conditions			
Physical characteristics	H × L × W (fan excluded) (mm)	667.5 × 598.3 × 452.5	667.5 × 704.3 × 452.5	715.8 × 520.7 × 704.3
	Weight (kg)	210	244	244
	Daily service points - positions	1 side service	1 side service	1 side service
	Ambient operating temps (°C)	-40 to +50	-40 to +50	-40 to +50
	Gradeability-all round (continuous) (deg)	25	25	25
Gradeability-all round (intermittent-1min) (deg)	35	35	35	
Cooling & lubrication	Heat rejection to coolant (includes oil cooler) (kW)	24	28	44
	Cooling fluid: 50/50 water/antifreeze	•	•	•
	CD oil capable SAE 5W40	•	•	•
Vibration	Max engine excitation at mounting locations	5g	5g	5g
Options	Brand	Kohler/Lombardini	Kohler/Lombardini	Kohler/Lombardini
Auxiliary PTOs (3rd & 4th) (optional)	Max torque (Nm)	100	100	100
	Drive ratio	1.23 times engine speed	1.23 times engine speed	1.23 times engine speed
	Provision for a double Gr.2 tandem hydraulic pump	•	•	•

KOHLER®

Lombardini s.r.l. is a part of Kohler Group.
Lombardini has manufacturing facilities in Italy, Slovakia and India
and sales subsidiaries in France, Germany, UK, Spain and Singapore.
Kohler/Lombardini reserves the right to make
modifications without prior notice.
www.kohlernewproject.com
www.lombardini.it

EUROPE
Lombardini Srl
Via Cav. del lavoro
A. Lombardini n° 2
42124 Reggio Emilia, Italy
T. +39 0522 38 91
F. +39 0522 389 503

USA & CANADA
Kohler Co.
444 Highland Drive,
Kohler - Wisconsin (53044), US
T. +1 920 457 4441
F. +1 920 459 1570